



RIV 123

Knife gate valve
with double-acting pneumatic jack
with O-ring gaskets



Tech drawings and tables

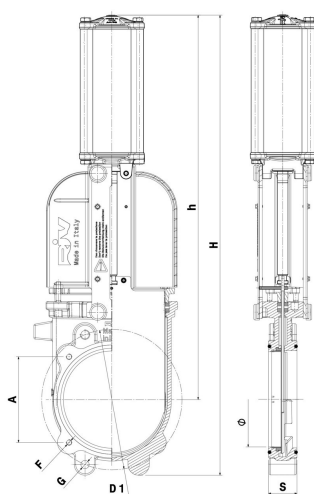

DN	Code	Ø	H	h	S	F	A	D1	G	PN	KG	P/box
4"	050123000016	100	664	558	50	M12	150	180	M16	10bar - 145psi	22,660	1
5"	050123000018	125	744	624	50	M12	150	210	M16	10bar - 145psi	23,175	1
6"	050123000019	150	814	680	60	M12	150	240	M20	10bar - 145psi	26,780	1
8"	050123000020	200	967	808	60	M12	180	295	M20	8bar - 120psi	31,415	1
10"	050123000021	250	1222	1025	70	-	-	350	M20	7bar - 100psi	58,710	1

Advantages

GLADIO is a gate valve where, in addition to the aesthetic side, our engineers have managed the particular features and details, trying not to leave anything to chance.

In order to be able to cover a wide range of use, GLADIO is standard equipped with double flanging, one for the fitting with square flange for agricultural use of standard dimensions and a DIN PN 10 one, or ANSI 150 for the American market.

Due to its special design feature, GLADIO is a gate valve called "anti-clogging" and can be installed in any position.

Large-size self-cleaning seat.

Security: GLADIO has a robust protective casing, which completely isolates the moving parts of the gate valve.

Set-up for manoeuvre lever attachments on the valve body and on the upper part.

Stainless steel screws and tie rods to prevent corrosion.

Equipped with an open/closed position indicator.

Simple maintenance: all parts, when worn out, are easily replaceable.

Complies with the Directive 97/23/CE (PED).

Technical data

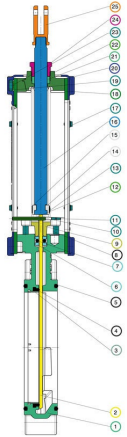

Materials			
1	Body	Cast iron	EN-GJL-250
2	Blade	Stainless steel	AISI 304
3	Ring	Stainless steel	AISI 304
4	Gasket	HNBR	
5	O-Ring	NBR	
6	Gland packing	Fibre	
7	Gasket	NBR	
8	Stud	Stainless steel	AISI 304
9	Gland packing box	Cast iron	EN-GJL-250
10	Washer	Stainless steel	AISI 304
11	Nut	Stainless steel	AISI 316
12	Position indicator	Steel	
13	Screw	Stainless steel	AISI 304
14	Blade connection	Brass	CW617N
15	Nut	Steel	Zinc-plated
16	Stem	Brass	CW614N
17	Screw	Stainless steel	AISI 304
18	Clamp	Steel	Zinc-plated
19	Screw	Stainless steel	AISI 304
20	Casing	PP	
21	Tow packing	Fibre	
22	Cap	Cast iron	EN-GJL-250
23	Washer	Stainless steel	AISI 304
24	Stuffing-box	Brass	CW614N
25	Fork	Brass	CW617N

Connections

Square flange / PN 10 - ANSI 150

Limit

-20°C (without liquid) +90°C

Notes

The max. working pressure (PN) means at a room temperature of about 23°C.

Approvals

